

NOTES:

1. THE CIRCUITS PROPOSED IN THIS RISER DIAGRAM SHALL BE FIELD VERIFIED PRIOR TO BID TO ASSURE THAT EACH CIRCUIT IS REUSEABLE OR NOT. EACH CIRCUIT THAT IS NOT REUSEABLE SHALL BE IDENTIFIED AND IT'S COST INCLUDED IN THE BASE BID PRICE. EXISTING ELECTRICAL CIRCUITS AND EQUIPMENT NOT BEING REUSEABLE SHALL HAVE NEW ELECTRICAL CIRCUITS INSTALLED AT NO ADDITIONAL COST. THERE ARE NO EXISTING DRAWINGS FOR BUILDING 50 DUE TO BEING LOST IN HURRICANE KATRINA.
2. CONTRACTOR SHALL PROVIDE PRICING FOR ALL NEW ELECTRICAL CIRCUITS IN BID TABLE AS AN ALTERNATE.
3. SUBSTITUTION OF HVAC EQUIPMENT THAT RESULTS IN THE EXISTING ELECTRICAL CIRCUITS AND EQUIPMENT NOT BEING REUSEABLE SHALL HAVE NEW ELECTRICAL CIRCUITS INSTALLED AT NO ADDITIONAL COST.
4. MCC DISCONNECTS REFERRED TO IN THE KEYNOTES ARE BY THE EXISTING FUSE SIZE AND EQUIPMENT SERVED.
5. RETURN UNUSED MCC RELAYS AND STARTERS TO ASPA.
6. SEE ASSOCIATED KEYNOTES AND PICTURES.

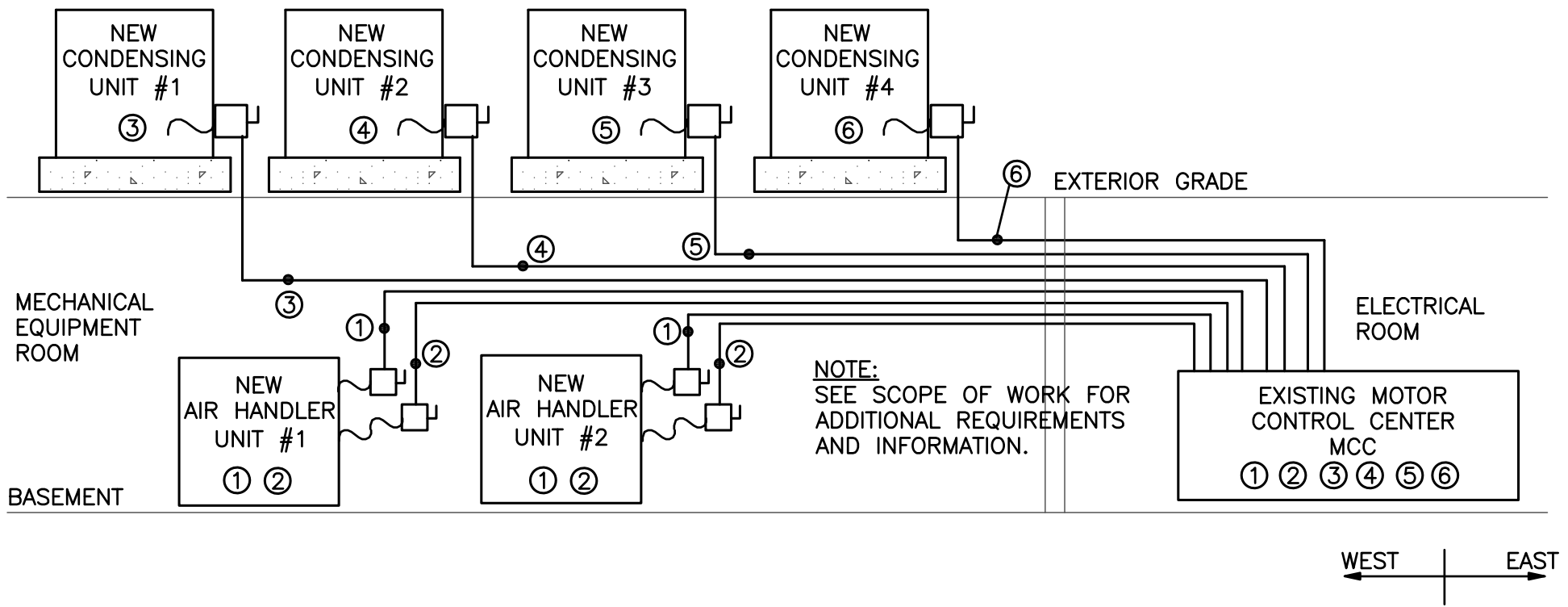

ONE LINE POWER RISER DIAGRAM – BUILDING 50
 NOT TO SCALE

KEYNOTES— BUILDING 50

- ① REUSE EXISTING MCC 125/3 BOILER HEATER #1 & 2 DISCONNECT SWITCH AND CIRCUIT. EXTEND CIRCUIT TO NEW DISCONNECT SWITCH AT AHU. FUSE BOTH DISC SWITCHES PER EQUIPMENT SUPPLIED. INSTALL NEW CONDUIT, WIRE, AND FLEX FROM NEW FUSED DISCONNECT SWITCH TO AHU 40 KW STRIP HEAT. TYPICAL FOR 2.
- ② REUSE EXISTING MCC 60/3 AHU HEATER #1 & 2 DISCONNECT SWITCH AND CIRCUIT. EXTEND CIRCUIT TO NEW DISCONNECT SWITCH AT AHU. FUSE BOTH DISC SWITCHES PER EQUIPMENT SUPPLIED. INSTALL NEW CONDUIT, WIRE, AND FLEX FROM NEW FUSED DISCONNECT SWITCH TO AHU 20 HP FAN SECTION. TYPICAL FOR 2.
- ③ REUSE EXISTING MCC 100/3 COMPRESSOR #1 DISCONNECT SWITCH AND CIRCUIT, EXTEND CIRCUIT FROM MECH ROOM TO NEW DISCONNECT SWITCH. FUSE BOTH DISC SWITCHES PER EQUIPMENT SUPPLIED. INSTALL NEW CONDUIT, WIRE, AND FLEX FROM DISCONNECT SWITCH TO SERVE 60 HP CONDENSING UNIT #1.
- ④ REUSE EXISTING MCC 100/3 COMPRESSOR #2 DISCONNECT SWITCH AND CIRCUIT, EXTEND CIRCUIT FROM MECH ROOM TO NEW DISCONNECT SWITCH. FUSE BOTH DISC SWITCHES PER EQUIPMENT SUPPLIED. INSTALL NEW CONDUIT, WIRE, AND FLEX FROM NEW FUSED DISCONNECT SWITCH TO SERVE 60 HP CONDENSING UNIT #2.
- ⑤ REUSE EXISTING MCC 100/3 COOLING TOWER DISCONNECT SWITCH AND AND INSTALL NEW CIRCUIT TO NEW DISCONNECT SWITCH. FUSE BOTH DISC SWITCHES PER EQUIPMENT SUPPLIED. INSTALL NEW CONDUIT, WIRE, AND FLEX FROM NEW FUSED DISCONNECT SWITCH TO SERVE CONDENSING UNIT #3.
- ⑥ REUSE EXISTING MCC 60/3 SPARE DISCONNECT SWITCH AND INSTALL NEW CIRCUIT TO NEW DISCONNECT SWITCH. FUSE BOTH DISC SWITCHES PER EQUIPMENT SUPPLIED. INSTALL NEW CONDUIT, WIRE, AND FLEX FROM NEW FUSED DISCONNECT SWITCH TO SERVE CONDENSING UNIT #4.

WEST ← | → EAST

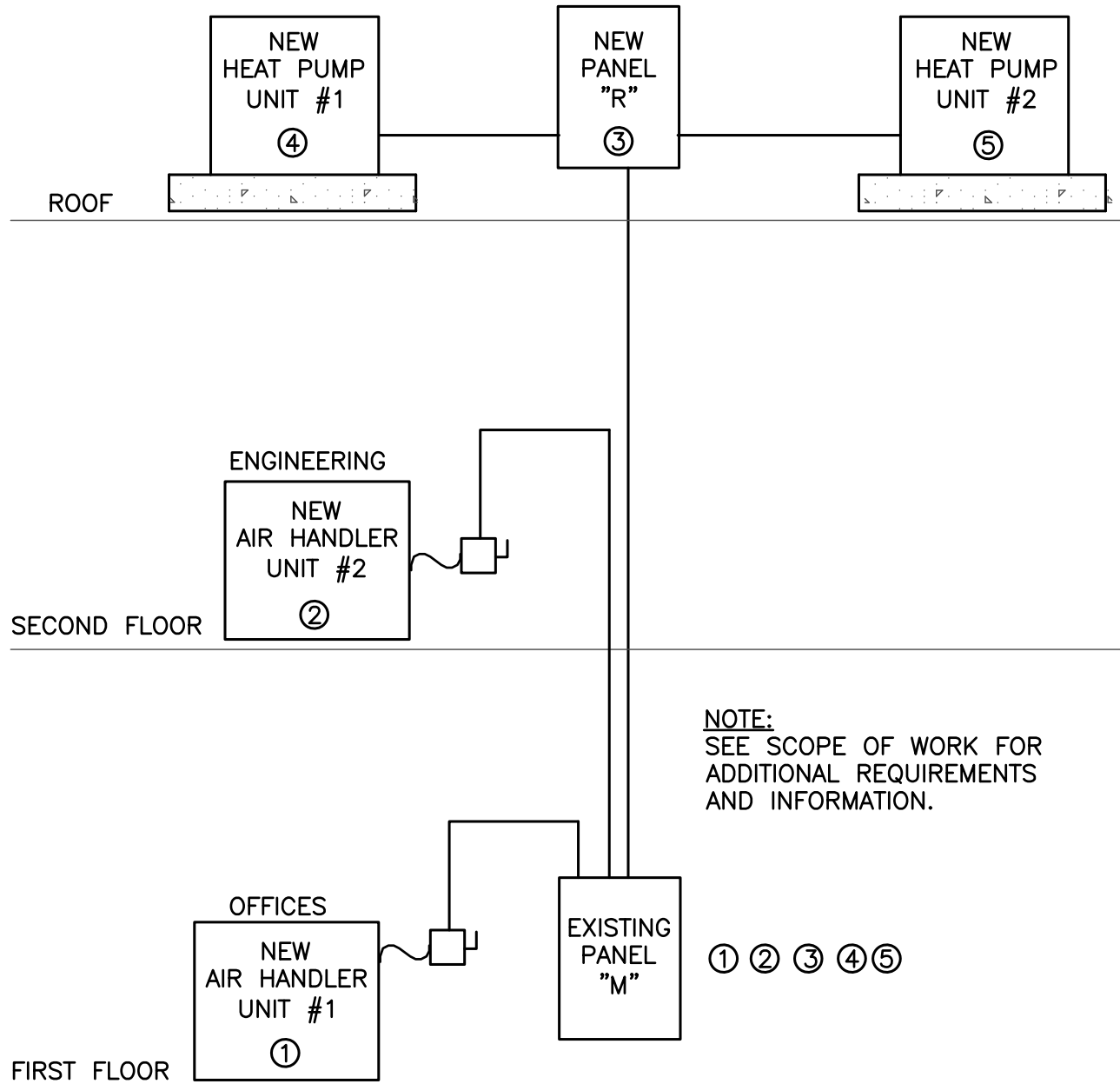

NOTES:

1. THE CIRCUITS PROPOSED IN THIS RISER DIAGRAM SHALL BE FIELD VERIFIED PRIOR TO BID TO ASSURE THAT EACH CIRCUIT IS REUSEABLE OR NOT. EACH CIRCUIT THAT IS NOT REUSEABLE SHALL BE IDENTIFIED AND IT'S COST INCLUDED IN THE BASE BID PRICE. EXISTING ELECTRICAL CIRCUITS AND EQUIPMENT NOT BEING REUSEABLE SHALL HAVE NEW ELECTRICAL CIRCUITS INSTALLED AT NO ADDITIONAL COST. THERE ARE NO EXISTING DRAWINGS FOR BUILDING 50 DUE TO BEING LOST IN HURRICANE KATRINA.
2. CONTRACTOR SHALL PROVIDE PRICING FOR ALL NEW ELECTRICAL CIRCUITS IN BID TABLE AS AN ALTERNATE.
3. SUBSTITUTION OF HVAC EQUIPMENT THAT RESULTS IN THE EXISTING ELECTRICAL CIRCUITS AND EQUIPMENT NOT BEING REUSEABLE SHALL HAVE NEW ELECTRICAL CIRCUITS INSTALLED AT NO ADDITIONAL COST.
4. SEE ASSOCIATED KEYNOTES AND PICTURES.

NOTE:
SEE SCOPE OF WORK FOR
ADDITIONAL REQUIREMENTS
AND INFORMATION.

ONE LINE POWER RISER DIAGRAM – ADMIN BLDG

NOT TO SCALE

KEYNOTES

- ① REUSE EXISTING 70/3 CIRCUIT BREAKER, CIRCUIT, AND DISCONNECT SWITCH. FUSE PER EQUIPMENT SUPPLIED. INSTALL NEW FLEX AND WIRE FROM DISCONNECT SWITCH TO SINGLE POINT CONNECTION TO SERVE AHU AND STRIP HEAT.
- ② REUSE EXISTING 100/3 CIRCUIT BREAKER, CIRCUIT, AND DISCONNECT SWITCH. FUSE PER EQUIPMENT SUPPLIED. INSTALL NEW FLEX AND WIRE FROM DISCONNECT SWITCH TO SINGLE POINT CONNECTION TO SERVE AHU AND STRIP HEAT.
- ③ REUSE EXISTING 150/3 CIRCUIT BREAKER AND 3-#2 CIRCUIT TO ROOF. INSTALL NEW SQUARE-D TYPE NF 125 AMP, 208 VOLT, 3 PHASE PANEL WITH LOCKABLE NEMA 4X ENCLOSURE. INSTALL GALVANIZED UNISTRUT SUPPORT FRAME. INSTALL HACR RATED CIRCUIT BREAKERS AND CIRCUIT TO SERVE CU #1 & CU #2. EXPOSED CONDUIT SHALL BE RGS AND WATERPROOF ARMORED FLEX. SUBSTITUTION OF HVAC EQUIPMENT THAT RESULTS IN THE EXISTING CIRCUIT NOT BEING USEABLE SHALL BE REPLACED AT NO ADDITIONAL COST.
- ④ MOUNT HEAT PUMP ON EXISTING PAD AS DIRECTED BY ASPA. ELEVATE TO 6" MIN ABOVE ROOF. INSTALL GALVANIZED PAN AND ROUTE CONDENSE LINE TO SCUPPER AT EDGE OF ROOF.
- ⑤ MOUNT HEAT PUMP ON DEMOLISHED COOLING TOWER'S EXISTING PAD AS DIRECTED BY ASPA. ELEVATE TO 6" MIN ABOVE ROOF. INSTALL GALVANIZED PAN AND ROUTE CONDENSE LINE TO SCUPPER AT EDGE OF ROOF.